

# BAYAMO



## FEATURES

- Easy assembly and installation
- **Indoor or outdoor use**
- Available in all Profils Systèmes exclusive colours: **Terra Cigala®**, **Profils Color®**, **Terre de Matières®**
- 25-year colour durability guarantee
- **Made in France**
- VOC emissions: **Class A+**

## 714 SERIES Custom-Made aluminium staircase

Bayamo® is a range of aluminium sections developed by Profils Systèmes for the house market for building straight staircases to any ordered size. Featuring easy assembly and installation, the Bayamo® aluminium staircase lends an unmistakably modern industrial look to your projet. Bayamo® staircases look just as good indoors as outdoors.



STRAIGHT DESIGN

### MODELS

3 models of staircases are proposed to adapt to the specificities of the project and the aspirations of the final customer :

- **Staircase with lateral stringer**, with aluminum step (possible covering, see options)
- **Staircase with single central stringer**, with aluminum or wood step and lacquered steel step support
- **Staircase with double central stringer**, with aluminum or wood step and lacquered aluminum step support

### TOTAL RISE OF FLIGHT

- **Up to 2900mm** with 35° angle
- **Up to 3600mm** with 45° angle
- **Up to 17 steps** (16 stairs + landing) with lateral stringer
- **Up to 16 steps** (last step on landing) with single or double central stringer

### RUN

**3600mm to 4200mm**

### ANGLE

**Angle variable from 35° to 45°**

NB : 35° to 40° is the comfort zone for a staircase in an individual home

### STRINGER

- Lateral stringer **up to 5100mm**
- Single or double central stringer **up to 5000mm**

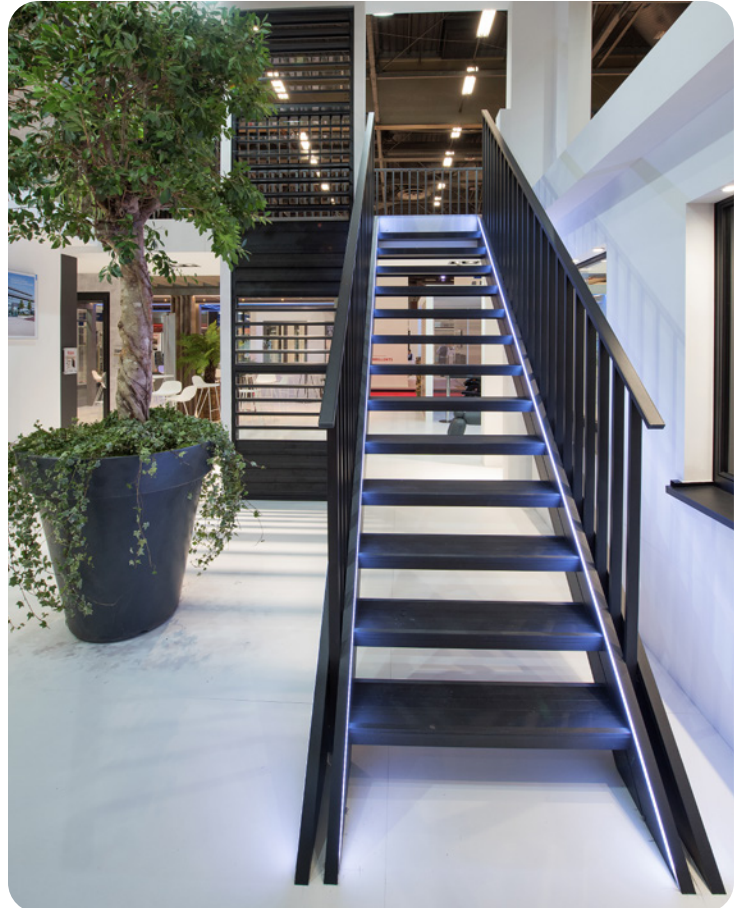

### RISE PER STAIR

**170mm to 210mm**

### TREAD

Depth **210mm to 270mm**

### STAIR WIDTH

- **Up to 1200mm** with lateral or single central stringer
- **Up to 2000mm** with double central stringer

**Profils**  
SYSTEMES

*Choose your profile*

# BAYAMO

## 714 SERIES Custom-Made aluminium staircase

MADE IN FRANCE



### WEIGHT CAPACITY

#### Lateral stringer staircase :

- Maximum weight for a 1200 mm step :  $\leq 167$  kg
- Maximum weight per staircase with 5100 mm stringer :  $\leq 900$  kg

#### Single central stringer staircase :

- Maximum weight for a 1200mm step :  $\leq 150$  kg
- Maximum weight per staircase with 5000 mm stringer :  $\leq 300$  kg

#### Staircase with double central stringer :

- Maximum weight for a 2000mm step :  $\leq 150$  kg
- Maximum weight per staircase with 5000 mm stringer :  $\leq 450$  kg

### GUARD RAILS

- **Macassar®** range guard rails can be surface fitted to sides for lateral stringer staircase
- **New Lhassa®** range guard rails can be horizontally fitted on step for single or double central stringer staircase

### LEGEND

- H = Total rise of flight, floor top to floor top
- R = Run  $R = 1H \leq R \leq 1,43H$
- A = Angle  $35^\circ \leq A \leq 45^\circ$
- LL = Stringer length  $LL \leq 5100$  or  $5000$
- h = rise per stair  $170 \leq h \leq 210$
- G = tread  $210 \leq G \leq 270$
- Blondel formula  $600 \leq 2h + G \leq 640$
- l = stair width  $\leq 1200$  or  $2000$

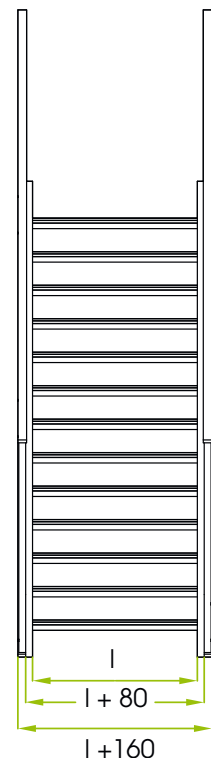
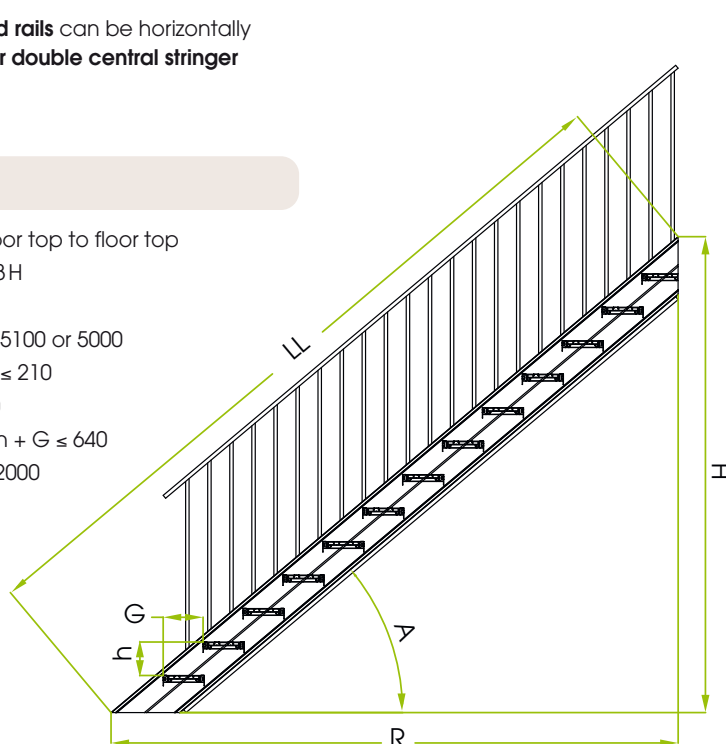

### FASTENINGS

- Stairway held in place by flange plates
- Guard rails bolted to stringer or on step

### ASSEMBLY

Robust assembly of staircase by bolting

### LATERAL STRINGER STAIRCASE OPTIONS

- LED Strip lighting on stringers and nosings
- Treads capped with wood or tiles



www.profil-systemes.com

Parc Activités Massane - 10 rue Alfred Sauvy  
34 670 Baillargues - France / Tél : +33 4 67 87 67 87

A Corialis affiliated company

**Profils**  
SYSTEMES

This guarantee is only available to professional retailers who are clients of Profils Systèmes, see terms and conditions of sale at [www.profil-systemes.com](http://www.profil-systemes.com) \* Certificat n°002-529