



FEATURES

- Large sizes, up to 6m
- Panels extremely rigid
- Quick to assemble
- Design of the sections and moulded parts
- Addition of motifs and edging in stainless steel look for a personalised gate
- Integration of full, pre-pierced or cut to measure panels
- Optional anti-finger trap gaskets
- Possibility of aluminium posts
- Available as pre-machined
- Available in all Profils Systèmes exclusive colours: Terra Cigala®, Maohé®, Eclats Métalliques®, Profils Color®, Terre de Matières®
- Colour hold guaranteed up to 25 years*

217.9 SERIES

aluminium gate with 40mm slats

A range of aluminium sections designed for the manufacture of **swing** gates (1 and 2 leaves) and **straight sliding** gates (Factory Spirit® design) with horizontal full or openwork slats, 40mm thick. The absence of any top or bottom crossbar, associated with wide 250mm aluminium slats gives the WOLF® gate a modern, pure-lined look.

STRAIGHT DESIGN

DIMENSIONS

Swing gate up to 5.5m wide

- Max. dimensions: W 5500 x H 2000mm
- Filling up to 10 slats

Gate up to 2.75m wide

- Max. dimensions:
 - Width: from 1 000 to 2 500mm
 - Height: from 1 497 to 2 462mm
- Filling up to 10 slats

Sliding gate up to 6m wide

- Max. dimensions: W 6000 x H 2000mm
- Filling up to 10 slats

Aluminium posts

4 dimensions available: 105 / 150 / 180 / 230mm

SLAT DESIGN

- **Horizontal** slats
- **Full** or **openwork** slats
- Stainless **steel look** or other colour edging
- **Full** or **machined** panels

SLATS

- Full slats L40 x H250mm, in extruded aluminium, making the panel particularly rigid
- Slats available in all the ranges of exclusive Profils Systèmes colours



MACHINING

- Reduced number of sections to be cut
- 4 identical machining types per leaf
- Simple, easy and quick manufacture
- Stamping possible for mounting the wheel on the sliding version

ASSEMBLY / HANGING

- The sections are interlocked to a depth of 65mm
- 6.3mm diameter hex cap stainless steel screws are used on an aluminium panel
- All screws are invisible
- The lock is embedded into the sections
- A support can be integrated without any visible crossbar
- No complex shapes, assembly is quick and easy

Profils
SYSTEMES

Choose your profile



217.9 SERIES

aluminium gate with 40mm slats

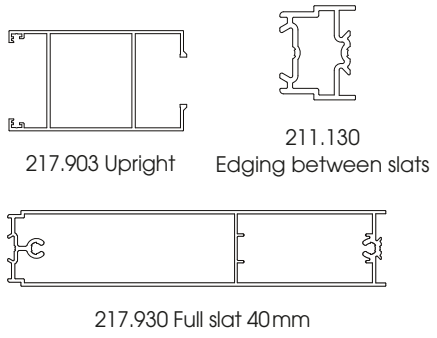

ACCESSORIES

- The main accessories can be supplied in the same colours as the gate
- All screws and fastening are in stainless steel or treated steel
- Wheel integrated into the section without machining, on the sliding version

MOTORISATION

- Compatible with motorisation systems available on the market (up to 150mm in height)
- Integrated support for motor, with no visible crossbar

PERSONALISATION

INTEGRATION OF PANELS

Stainless steel look or decorative panels



INTEGRATION OF NUMEROUS MOTIFS

Stainless steel look or decorative panels

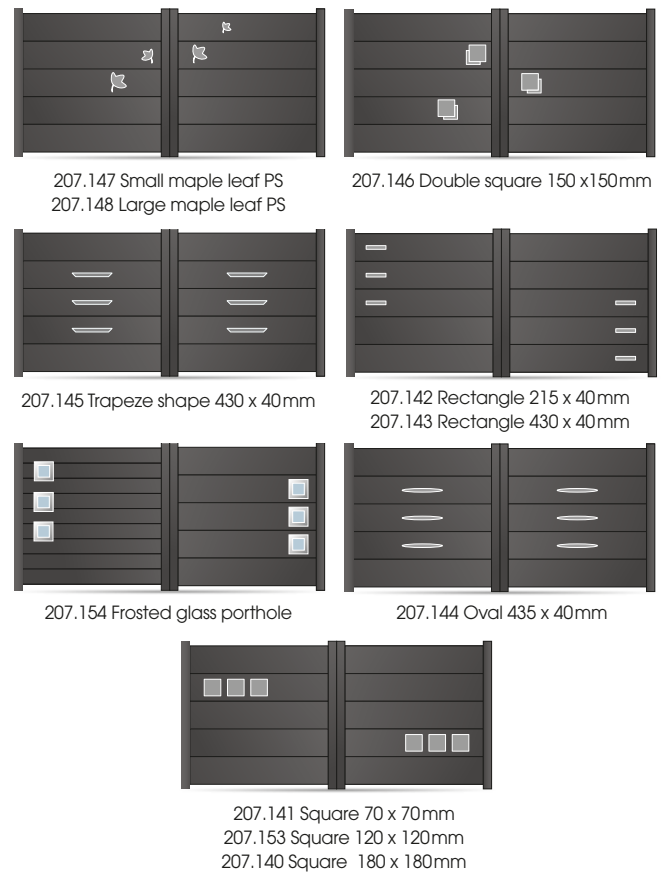

INTEGRATION OF THE NEW CANBERRA® HANDLES



INTEGRATED EDGING

Stainless steel colour (or other colour)



Ref: 094_286 - Photo: AdobeStock.com, Profils Systemes Asteroid for Profils Systemes - Update 10/2019 Save the planet: use less plastic and paper PEFC - 10-32-3010/ PEFC Certified / Printed on paper produced from sustainably managed forests and certified so